

W. N. LOCKWOOD.

Ox-Yoke.

No. 28,384.

Patented May 22, 1860.

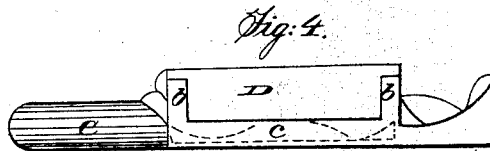
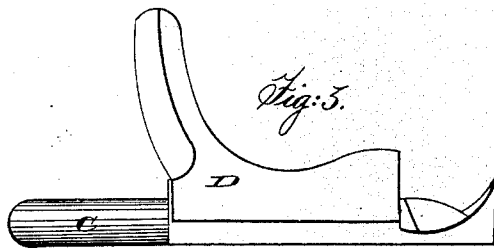
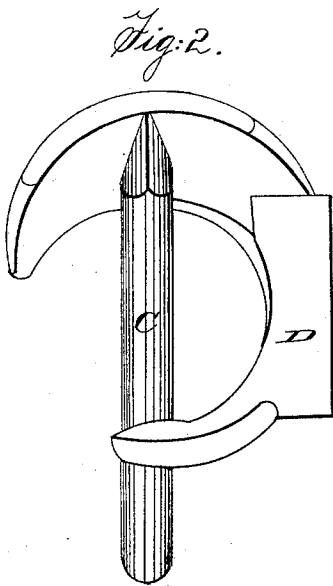
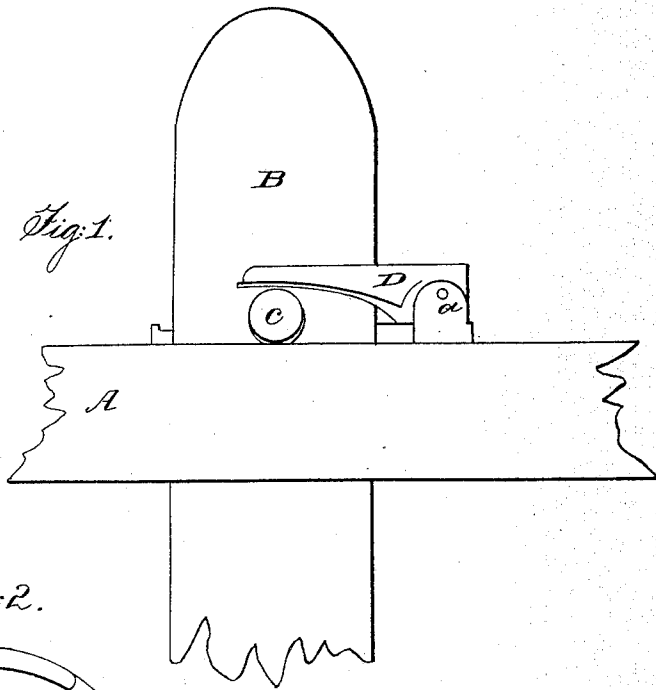

Witnesses  
Wm. L. Stevenson  
Franklin W. Beckley

Inventor  
Wm. N. Lockwood

# UNITED STATES PATENT OFFICE.

WILLIAM N. LOCKWOOD, OF NEW BRITAIN, CONNECTICUT.

## OX-YOKE FASTENING.

Specification of Letters Patent No. 28,384, dated May 22, 1860.

*To all whom it may concern:*

Be it known that I, WILLIAM N. LOCKWOOD, of New Britain, Hartford county, State of Connecticut, have invented a new and Improved Bow-Pin for Securing Ox-Bows to Yokes, &c.; and I do hereby declare the following to be a full, clear, and exact description thereof, reference being had to the accompanying drawings and letters of reference thereon, making part of this specification.

Of the said drawings Figure 1 shows an end elevation of the pin when inserted in a bow. Fig. 2 is a perspective view of the pin. Figs. 3 and 4 are side elevations.

Similar letters of reference indicate like parts in all the drawings.

To enable others skilled in the art to make and use my invention I will proceed to describe its construction and operation.

A represents a yoke or part of one having a hole for inserting the bow B.

C is the pin which passes through the bow.

D, is a hinged bar or horn which fastens and secures the pin to the bow.

Operation: The operation will be as follows. The bow being inserted in the yoke, the horn D, which is hinged by a pin (a), passing through the ears (b b,) and a portion of which rests on the spring (c), is raised as seen in Fig. 3, and the pin inserted in the bow, and the horn pushed down as shown in Figs. 1 and 2, and forms a perfect fastening, the spring holding it permanently in place. To withdraw the pin, it is only necessary to raise the horn as shown in Fig. 3.

Having thus described my invention I will state what I desire to secure by Letters Patent.

The pin C, and horn D, attached to the same stock as described, and operating in combination with the ox bow B, as a fastening for ox yokes substantially as set forth.

WM. N. LOCKWOOD. [L. S.]

Witnesses:

WM. L. HUMASON,

FRANKLIN W. BECKLEY.